



Instruction manual

DE – ACHTUNG: Die Verwendung des INNOTECH-Produkts ist erst zulässig, nachdem die Gebrauchsanleitung in der jeweiligen Landessprache vollständig gelesen und verstanden wurde.

EN – ATTENTION: Use of the INNOTECH product is only permitted after the instruction manual has been read and fully understood in the respective language.

IT – ATTENZIONE: L'utilizzo del prodotto INNOTECH è permesso solo previa lettura e comprensione dell'intero manuale di istruzioni nella lingua del relativo paese di utilizzo.

FR – ATTENTION : L'utilisation du produit INNOTECH n'est autorisée qu'après avoir entièrement lu et compris la notice d'utilisation dans la langue du pays concerné.

NL – ATTENTIE: Dit INNOTECH-product mag pas gebruikt worden nadat u de gebruikershandleiding in de taal van het betreffende land gelezen en begrepen hebt.

ES – ATENCIÓN: Se autorizará el uso de los productos INNOTECH una vez que se hayan leído y entendido las instrucciones de uso en el idioma del país.

PT – ATENÇÃO: O uso do produto INNOTECH apenas é permitido depois de ter lido e compreendido na totalidade as instruções de uso na respetiva língua nacional.

DK – GIV AGT: Du må først bruge et produkt fra INNOTECH, efter du har læst og forstået brugsvejledningen i fuldt omfang i dit lands sprog.

SV – O B S : Denna INNOTECH-produkt får inte användas förrän bruksanvisningen på respektive lands språk har lästs igenom och förstås.

CZ – POZOR: Práce s výrobkem INNOTECH je povolena teprve po kompletním přečtení a porozumění návodu k použití v jazyku daného státu.

PL – UWAGA: Produkty firmy INNOTECH mogą być używane dopiero po dokładnym zapoznaniu się z całą instrukcją obsługi w ojczystym języku.

SL – POZOR: Uporaba izdelka INNOTECH je dovoljena šele po tem, ko ste navodila prebrali v celoti v ustreznem jeziku svoje dežele in jih tudi razumeli.

SK – POZOR: Produkt INNOTECH môžete používať až po prečítaní a porozumení celého návodu na použitie pre príslušnú krajinu.

HU – FIGYELEM: Az INNOTECH termékek használatát csak azt követően engedélyezett, hogy saját nyelven elolvasta és megértette a teljes használati utasítást.

TR – DİKKAT: INNOTECH ürününün kullanımına ancak ilgili ülkenin dilinde sunulmuş olan kullanım kılavuzunun tamamen okunmasından ve anlaşıldığından sonra izin verilir.

ZH – 注意 : 只有在仔细阅读并完全理解了当地语言的使用说明后，才能使用 INNOTECH 公司的产品。

DE

EN

IT

FR

NL

ES

PT

DK

SV

CZ

PL

SL

SK

HU

TR

ZH

[2]	DESCRIPTION OF SYMBOLS	3
[3]	SAFETY INSTRUCTIONS	4
[4]	COMPONENTS/MATERIAL	6
[5]	PRODUCT APPLICATION/APPROVAL	10
[6]	INSPECTION	11
[7]	WARRANTY	12
[8]	SIGNS & MARKINGS	13
[9]	INSTALLATION INSTRUCTIONS	15
[10]	SYSTEM SPACING	15
[11]	INCORRECT USE	15
[12]	FALL HEIGHT	16
[13]	ASSEMBLY	22
[14]	SYSTEM ASSEMBLY	23
[15]	MAINTENANCE & DISPOSAL	27
[16]	ACCEPTANCE REPORT	28
[17]	FALL PREVENTION SYSTEM NOTICE	30
[18]	INSPECTION REPORT	31
[19]	DEVELOPMENT & SALES	33

Warnings / Danger notices

For an IMMEDIATE danger, which could lead to severe injury or death.



For a POTENTIALLY dangerous situation, which could lead to severe injury or death.



For a POTENTIALLY dangerous situation, which could lead to injuries and property damage.



Wear protective gloves!



Wear protective glasses!

**Additional information/notice**

correct



incorrect



Follow the manufacturer's instructions/the respective user manuals.

The following safety instructions and the latest technological standards must be taken into account.

3.1 GENERAL

- The safety system may only be assembled according to the latest technological standards and by an appropriately trained, competent professional who is familiar with the safety system.
- The protective equipment may only be installed or used by persons who:
 - are trained in the use of "Personal Protective Equipment"(PPE),
 - are physically and psychologically fit(health restrictions such as heart/ circulatory problems, medication, alcohol consumption, etc. compromise the user's safety).
 - are familiar with the locally applicable safety regulations.
- All applicable accident prevention rules(e.g. those for work on roofs) must be followed during installation and use of the safety system.
- An emergency plan must be available which includes rescue measures for all possible emergencies.
- Before works begin, measures must be taken to ensure that no objects can fall down from the workspace. The area under the workspace (sidewalk, etc.) must be kept clear.
- The fall prevention system should be planned, installed and used in such a way that proper use of the personal protective equipment(PPE) makes a fall over the edge impossible. (See planning documents at www.innotech.at).
- The fall prevention system is subject to maximum load limits. These can be found on the type plate of the fall prevention system and may not be exceeded.
- The type plate of the fall prevention system is to be applied in a location which is easily visible for the user.
- The positions of the anchor points are to be visibly documented (e.g. with a sketch of the rooftop) at the access point to the roof safety system.
- After being subjected to the stress of a fall, the entire safety system is to be taken out of operation and inspected by a qualified professional (component parts, fastenings to the substructure, etc.).
- The safety system must not be altered in any way.
- If access to the safety system is granted to external contractors, their familiarity with this user manual is to be confirmed in writing.
- Should the equipment be sold to a customer abroad, the user manual is to be provided in the appropriate local language.
- Local lightning protection regulations are to be observed.



Should any confusion arise during installation, the manufacturer must be contacted.

3.2 FOR FITTERS: FOR SAFE INSTALLATION

- All stainless steel screws are to be treated with an appropriate lubricant before installation (included: Weicon AntiSeize ASW 10000 or equivalent).
- Stainless steel may not come into contact with sanding dust or steel tools, as this can lead to corrosion.
- The fitters must ensure that the substructure is appropriate for the fastening of the anchoring materials. In case of doubt, consult a structural engineer.
- The roof covering must be sealed according to the appropriate regulations.
- In areas with significant snowfall, the fall prevention system is to be installed near the roof ridge.
- Proper fastening of the safety system must be documented with fastening reports and photos of the respective circumstances of installation.

3.3 FOR USERS: FOR SAFE USE

- To ensure safe entry/ascent to the fall prevention system, all necessary work safety regulations must be followed.
- Attachment to the fall protection system is completed with the cable slider IND-GLEIT-10. The INNOTECH cable slider may only be used together with original carabiners, the INNOTECH "ALLinONE" horizontal lifeline system and personal protective equipment in accordance with EN 361 (safety harness) and EN 363(fall arrest system).
- If the cable length has been installed as a restraint system: when using the cable length, a cable shortener must be used to set the connecting element in such a way that a fall is impossible.
- The minimum free space necessary under the edge is calculated as follows: Deformation of the anchor device in case of stress + manufacturer's specification of the personal protective equipment used, including deflection of the cable + body height + 1 m safety margin.
- For horizontal use, only such connecting elements can be used which are designed for this purpose and tested for the respective edge type (sharp edges, trapezoidal sheet, steel girders, concrete, etc.).
- Proper use of the individual components, including the "Personal Protective Equipment" must be ensured, since the effectiveness of the fall prevention system is otherwise NOT guaranteed.
- Do NOT use fall arrest systems if wind speeds exceed normal parameters.
- After heavy storms, the metal roof system (substructure) is to be inspected before continued use of the fall prevention system.
- On slanted roofs, the proper snow-catching features must be added to prevent ice or snow from sliding from the roof surface.
- The fall protection system must NOT be used by children or pregnant women.

4.1 COMPONENTS

Instruction manual



Type plate



4.2 IND-COMPONENTS (NOT INCLUDED!)

IND-SEIL-40: Stainless steel AISI 316, \varnothing 10 mm, 7x19

IND-ENDS-10: Aluminium EN AW-6060 T66, Stainless steel AISI 303

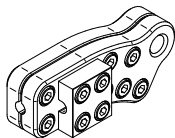
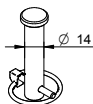
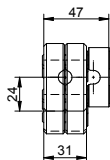
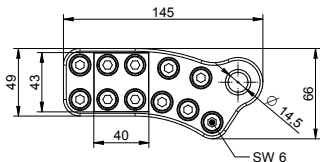

4.3 IND-COMPONENTS (NOT INCLUDED!)

IND-EB-10: Coated steel

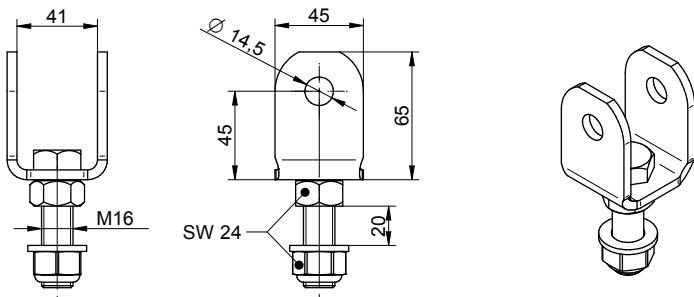

IND-EB-20: Coated steel

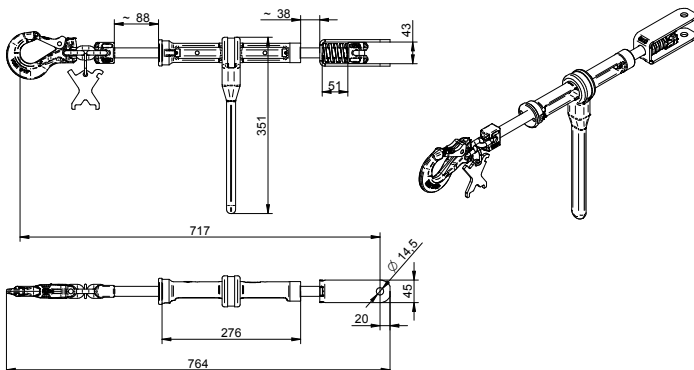

4.4 IND-COMPONENTS (NOT INCLUDED IN DELIVERY!)

IND-EB-30: Coated steel

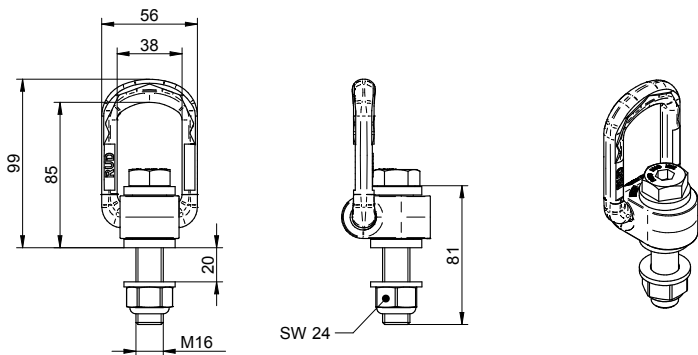

IND-GLEIT-10 Cable slider: Stainless steel AISI 316
detachable, can pass over curves



INNOTECH "IND-GLEITER" should only be used with original INNOTECH karabiners, INNOTECH stainless steel cable and personal protective equipment (safety harness EN 361).

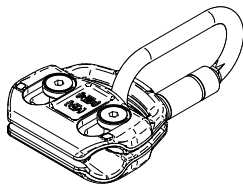
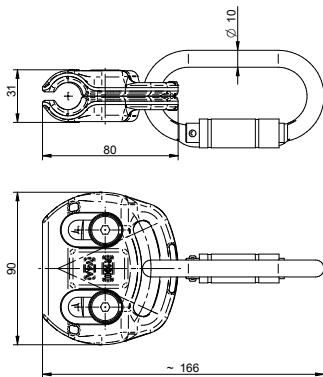

INNOTECH "IND-TEMP" was developed as a **lifeline system** for personal fall prevention and is suitable for the following fall prevention systems as per EN 363:2008:

- Restraint systems
- Fall arrest systems
- Rescue systems



The maximum number of persons to be secured is visible on the type plate.



DANGER OF DEATH if used incorrectly.

- Use INNOTECH "IND-TEMP" ONLY for personal safety.
- NEVER hang loads from the INNOTECH "IND-TEMP" which have NOT been expressly approved in this instruction manual.



Follow the manufacturer specifications of the personal protective equipment used.

INNOTECH "IND-TEMP" has been tested and certified in accordance with **EN 795:2012 TYP C.**

The authority notified for type testing:

IBS-Institut für Brandschutztechnik und Sicherheitsforschung GmbH,
Petzoldstraße 45, 4017 Linz/Austria

6.1 INSPECT BEFORE EACH USE

INNOTECH "IND-TEMP" must be checked visually before each use for any obvious defects.



DANGER OF DEATH if the INNOTECH "IND-TEMP" is damaged.

- INNOTECH "IND-TEMP" must be in faultless condition.
- Do NOT use INNOTECH "IND-TEMP" if:
 - damage or wear on the components is visible.
 - any other defects have been observed (loose screw connections, deformations, corrosion, wear...),
 - strain has occurred due to a fall (exception: first aid administration). (check the INNOTECH „IND-EB-20“ cable pre-tension and spring length),
 - the product designation is illegible.

Check the entire fall protection system's suitability for use with the help of the acceptance and inspection reports.



If there are any doubts concerning the reliable operation of the fall protection system, it must NOT be used until being checked by a qualified professional (with written documentation). If necessary, replace the product.

6.2 ANNUAL INSPECTIONS

INNOTECH "IND-TEMP" must be inspected at least once annually by a qualified professional who is familiar with the system. The safety of the user depends on the effectiveness and durability of the equipment.

Shorter inspection intervals may be necessary, depending on the intensity and environment of use (e.g. in a corrosive atmosphere, etc.).

Document the inspection by the qualified professional in the inspection report included in the instruction manual and keep it on record with the manual.



Inspection intervals are found in the inspection report.

6.3 INSPECTION OF SAFETY HARNESS AND FASTENINGS

Inspect the safety harness and fastenings according to the instruction manuals.

The warranty period for manufacturing defects on all components (under normal conditions of use) is 2 years from the date of purchase. The term is shortened if they are used in corrosive atmospheres.

If there is a strain (fall, weight of snow, etc.) the warranty claim is void for those components that have been designed to absorb energy or that may have been deformed.



For system installation and for components planned and installed under the responsibility of specialised professional installation companies, INNOTECH neither assumes responsibility nor is it bound by warranty in the case of improper installation.

8.1 INNOTECH "IND-TEMP" AS TYPE C SYSTEM

- A) Name or logo of the manufacturer/seller: INNOTECH
 B) Type designation: IND-TEMP
 C) Sign that the instruction manual must be followed: 
 D) Maximum number of people who can be secured: 4 (including 1 person for first aid administration)
 E) Number of the applicable norm: EN 795:2012 TYP C
 F) Maximum cable deviation: 1.2 m
 G) Designation: Cable type nr:
 H) Shock absorber: YES
 I) Installation date: Installation year: ☒
 J) Date of the next annual inspection: Date of the next annual inspection
 K) Name & address of the fitting company: Installed by

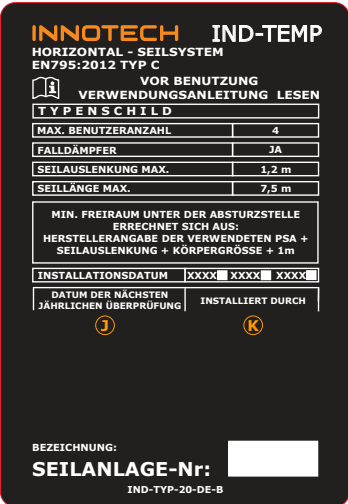

INNOTECH IND-TEMP

HORIZONTAL - SEILSYSTEM
 EN795:2012 TYP C

 VOR BENUTZUNG
 VERWENDUNGSANLEITUNG LESEN

TYPENSCHILD

MAX. BENUTZERANZAHL	4
FALLDÄMPFER	JA
SEILAULENKUNG MAX.	1,2 m
SEILLÄNGE MAX.	7,5 m

MIN. FREIRAUM UNTER DER ABSTURZSTELLE
 ERRECHNET SICH AUS:
 HERSTELLERANGABE DER VERWENDETEN PSA +
 SEILAULENKUNG + KÖRPERGRÖSSE + 1m

INSTALLATIONSdatum XXXX XXXX XXXX

Datum der nächsten
 JÄHRLICHEN ÜBERPRÜFUNG

INSTALLIERT DURCH

BEZEICHNUNG:

SEILANLAGE-Nr:

IND-TYP-20-DE-B

8.2 INNOTECH "IND-GLEIT-10"

- | | |
|---|---|
| <p>A) Name or logo of the manufacturer/seller:</p> <p>B) Type designation:</p> <p>C) Sign that the instruction manual must be followed:</p> <p>D) Maximum number of people who can be secured:</p> <p>E) Number of the applicable norm:</p> <p>F) Year made and manufacturer's serial number:</p> | <p>INNOTECH
IND-GLEIT-10</p> <p></p> <p>1 Person
EN 795:2012 TYP C
YYYY-...-</p> |
|---|---|

A

INNOTECH

B

Seilgleiter
IND-GLEIT-10

C



D



E

EN 795:2012
TYP C

F

JJJJ-...-

9

INSTALLATION INSTRUCTIONS

Apply the appropriate type plate at every system entrance.

Installation substructure: Steel construction

System spacing: **L = up to 7.5 m**

Force at end point = max. 25 kN (stability of the steel construction)

max. cable deviation = 1.2 m cable deviation

10 SYSTEM SPACING

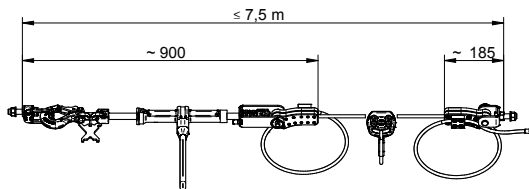

11 IMPROPER USE

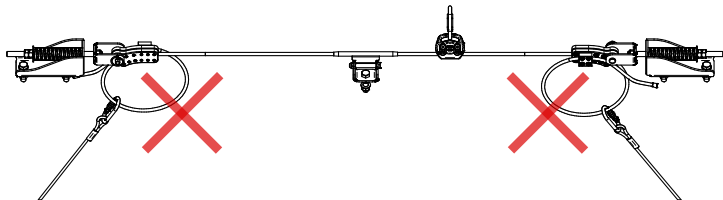

Keep the fastening elements as short as possible.

Be aware of the fall height!

When working with low fall heights (canopies, balconies, etc.), the personal protective equipment must be adjusted accordingly. Restraint or support systems are to be used in accordance with applicable norms or work safety regulations.

Restraint system as per EN 363

With restraint systems, a free fall should be avoided. Correct use of the fall prevention system and the use of appropriate fasteners or cable shorteners should prevent the person from getting into a free-fall situation.

Each person who works in areas where the risk of a fall is present must see to it that the personal protective equipment he/she uses meets the relevant norms and that the connection to the anchor system is kept as short as possible, in order to avoid a fall scenario.

Labeling

If sections are established for use as a restraint system, these are to be designated as such with additional type plates which are mounted directly and permanently at the beginning and end of these sections.

12.1 CALCULATION OF MINIMUM FALL HEIGHTS

Example 1

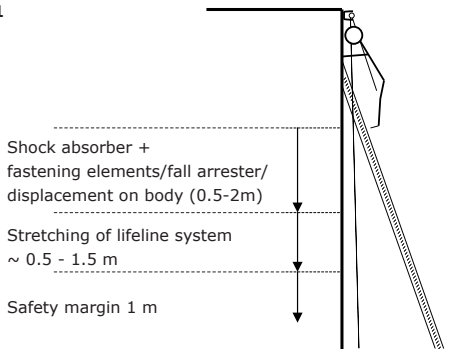

Assumption: Total lifeline system length 100 m and support spacing 15 m

Example 2

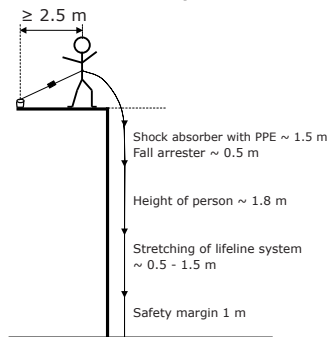

Example 3

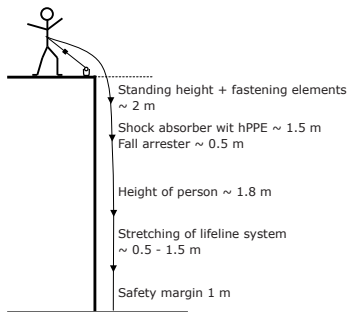

13 INSTALLATION

13.1 ATTACH END LOCK TO LOOSE CABLE END

1.

Open the end lock as far as the screw safety catch allows.



SW = 6



SW = 6

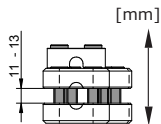
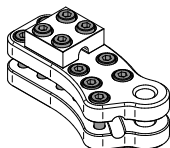
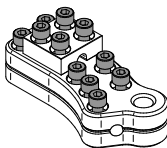

2.

Attach one of the included \varnothing 10 mm plastic protective caps to the end of the cable.



3.

At a distance of at least 1000 mm from the cable end, the stainless steel cable is pushed into the interior of the end lock and closed by hand.



[mm]

Original INNOTECH \varnothing 10 mm stainless steel cable "IND-SEIL-40"

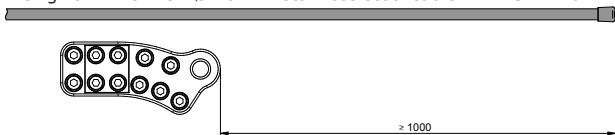

13 INSTALLATION

4.

Push the stainless steel cable into the existing groove.

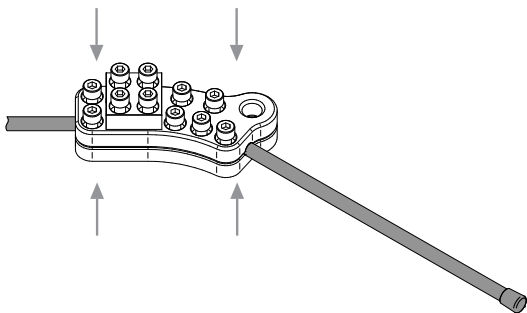
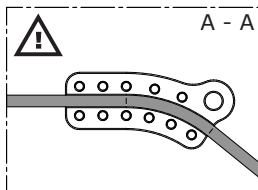
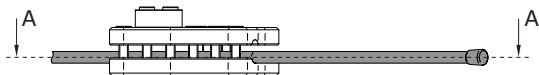

13 INSTALLATION

5.



SW = 6



SW = 6



7 x 15 Nm
SW 6

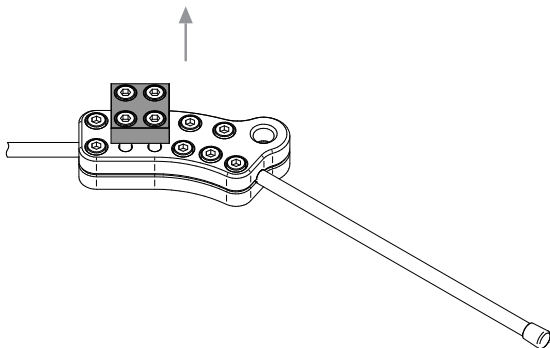
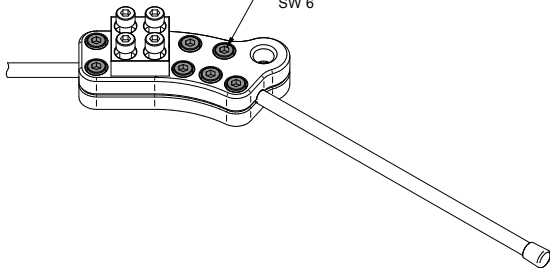

13 INSTALLATION

6.

Create a cable loop with \varnothing 300 mm and thread through the clamp opening.



[mm]

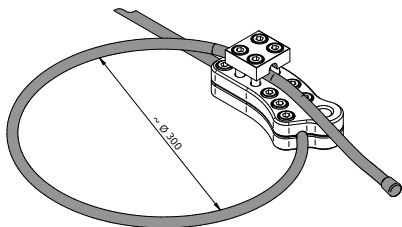

The stainless steel cable must not be squeezed outside of the guiding grooves!

7.

Secure the screw lock as illustrated.



SW = 6



SW = 6

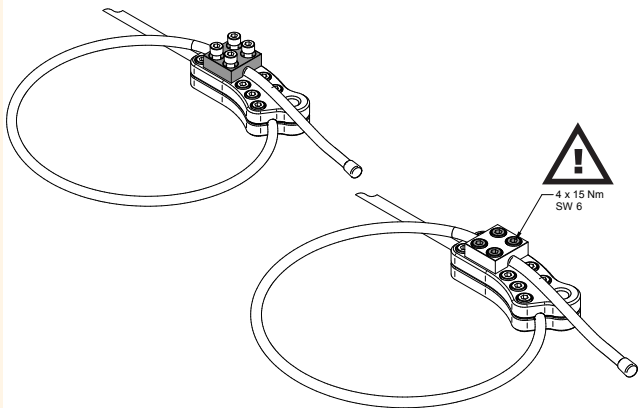

13 INSTALLATION

8.

Connect the end lock to the IND-EB-40 with bolt and peg.

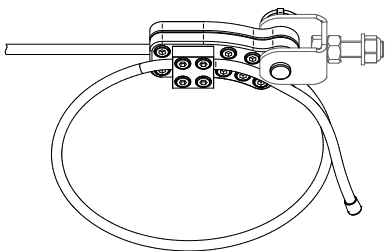
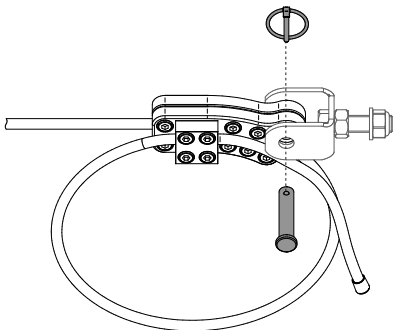

1.

Connection of IND-EB-10 and IND-ENDS-10.

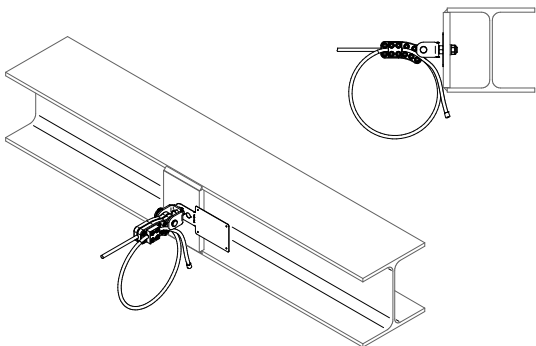

2.

Installation of IND-EB-30.

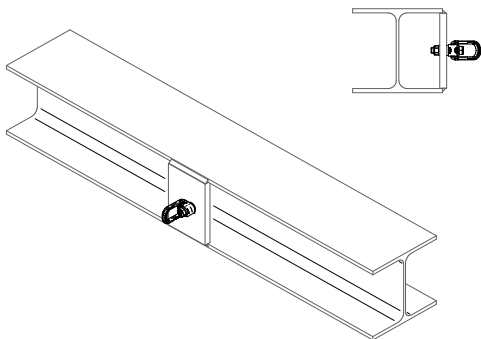

3.

IND-TEMP cable length adjustment.

[mm]

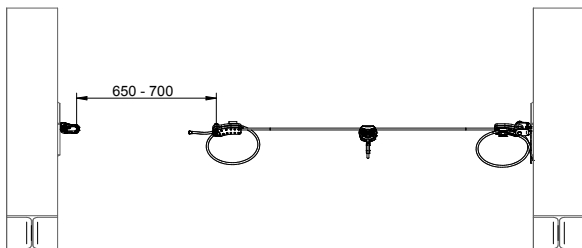

4.

Mounting IND-EB-20 on IND-ENDS-10 with bolt and pin.

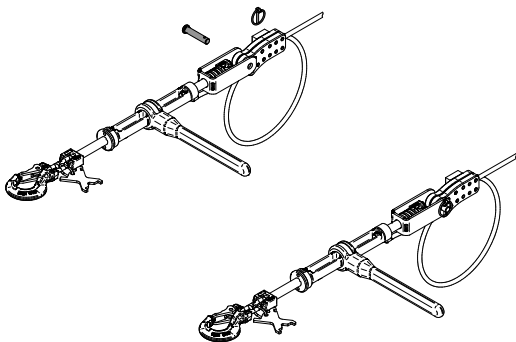

5.

Connecting IND-EB-20 with IND-EB-30. [51 mm = 0 kg]

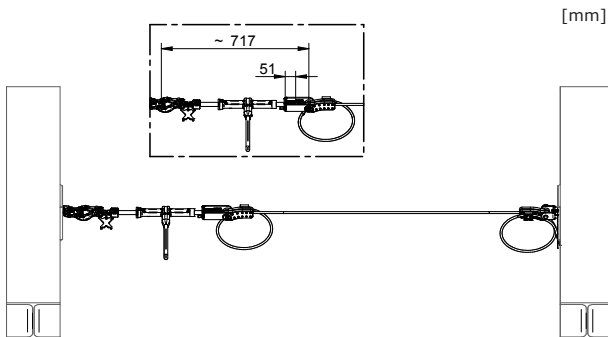

6.

Adding pretension to the system. [30-32 mm = 300 kg]

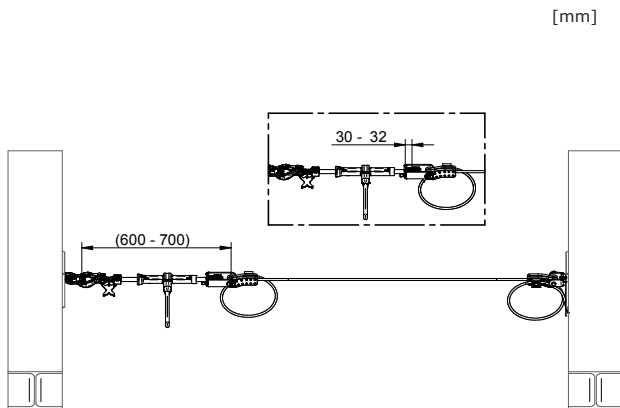

7.

System overview, with positioning of the slider.

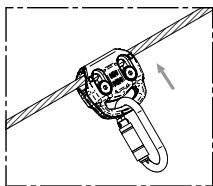
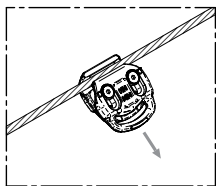
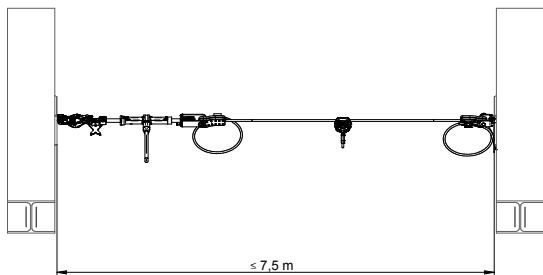

8.

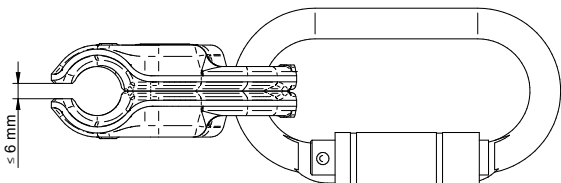

The gap width must not exceed 6 mm when in the closed position!

15.1 MAINTENANCE

Keep the stainless steel cable free of grease, ice and snow!
If the stainless steel cable becomes heavily soiled, it is to be cleaned with a cloth.

15.2 DISPOSAL

Do NOT dispose of the fall protection system in the house waste.
Following national requirements, gather the used parts and dispose of them in an environmentally responsible fashion.

ACCEPTANCE REPORT NR. _____ (PART 1/2)

TEMPORARY LIFELINE SYSTEM Ø 10MM AS PER EN 795 TYP C

CONTRACT NUMBER:

PROJECT:

CUSTOMER: Specialist:

Company address:

CONTRACTOR: Specialist:

Company address:

INSTALLATION: TEMPORARY LIFELINE SYSTEM Ø 10 mm as per EN 795 TYP C**DESIGNATION:** Cable type nr.: _____Specialist:

Company address:

INSTALLATION: Fastening points of the horizontal lifeline system Ø 10 mmSpecialist:

Company address:

DOCUMENTATION OF FASTENINGS/PHOTO-DOCUMENTATION

PRODUCT: Pcs. _____ Year /Serial nr.: _____

(Type designation of fastening point)

INSTALLATION SUBSTRUCTURE: _____

(e.g solid concrete grade: C20/25; wood, rafter dimensions; for sheet roofs: roof manufacturer, profile, material, sheet thickness, etc.)

Date:	Location:	Anchor type: Fastening/ adhesive type	Seat depth: [mm]	Drill Ø: [mm]	Tightening torque:	Photos: (Save directory)
			mm	mm	Nm	

VARYING FASTENINGS /FASTENING POINTS (TYPES, INSTALLATION SUBSTRUCTURES, SERIAL NUMBERS, ETC.) MUST BE LISTED SEPARATELY!

PRODUCT: Pcs. _____ Year/Serial nr.: _____

(Type designation of fastening point)

INSTALLATION SUBSTRUCTURE: _____

(e.g solid concrete grade: C20/25; wood, rafter dimensions; for sheet roofs: roof manufacturer, profile, material, sheet thickness, etc.)

Date:	Location:	Anchor type: Fastening/ adhesive type	Seat depth: [mm]	Drill Ø: [mm]	Tightening torque:	Photos: (Save directory)
			mm	mm	Nm	

ACCEPTANCE REPORT NR. _____ (PART 2/2)

TEMPORARY LIFELINE SYSTEM Ø 10MM AS PER EN 795 TYP C

THE MINIMUM STABILITY OF ANCHOR POINTS (IN STEEL CONSTRUCTION)
OF 25 kN IS PRESENT.

The undersigned installation company ensures the correctness of their work (edge spacing, inspection of the substructure, proper cleaning of drill holes, observation of hardening times, working temperature and screw manufacturer guidelines, etc.). The customer accepts the services of the contractor. The instruction manuals, fastening documentations/ photo-documentations, and inspection reports were given to the customer (building owner) and are to be made available to the user. At the point of access to the fall prevention system, the positions of the anchor points are to be documented by the building owner by means of plans (e.g. sketches of the rooftop).

The contractor, a qualified professional who is familiar with the fall prevention system, confirms that the installation was performed correctly, up to the latest technological standards and according to the manufacturer's instruction manual. The reliability and safety is confirmed by the contracting company.

Delivery of: (e.g. cable sliders, personal protective equipment (PPE), fall arrester (HSG), storage cabinet, etc.)

Pcs. _____ Pcs. _____ Pcs. _____ Pcs. _____

Incorporated into existing lightning protection system? Yes No

Comments: _____

Name: _____
Customer

Fitter of fastening points

Date, company seal, signature

Date, company seal, signature

Fitter of horizontal lifeline system

Date, company seal, signature

**INFORMATION ON THE
FALL PREVENTION SYSTEM**

The building owner is to make this notice visible at the system access point!

Use of the system must be up to technological standards
and the instruction manuals.

Instruction manuals, inspection reports, etc. are kept in:

Overview of the area with the position of anchor point:

Areas where falling through could occur (e.g. skylights and/or strip lights) must be marked!

The maximum load capacities of the anchor points are stated in the respective
instruction manuals or the type plate of the fall prevention system.

If subjected to the stress of a fall or in case of doubt, the anchor point is to be removed from use immediately and
sent to the manufacturer or a qualified repair facility for inspection and repair.

This also applies to damages to the fastening components.

INSPECTION REPORT NR. _____ (Part 1/2)

TEMPORARY LIFELINE SYSTEM Ø 10MM AS PER EN 795 TYP C

CONTRACT NUMBER: _____

PROJECT: _____

PRODUCT: Horizontal lifeline system Cable type nr. _____

ANNUAL SYSTEM INSPECTION COMPLETED ON: _____

ANNUAL SYSTEM INSPECTION TO BE COMPLETED BY: _____

CUSTOMER: _____ Specialist: _____ 
Company address: _____CONTRACTOR: _____ Specialist: _____ 
Company address: _____

INSPECTION POINTS: <input checked="" type="checkbox"/> checked and in order!	OBSERVED DEFECTS: (Description of defect/ Measures to be taken)
DOCUMENTATION:	
<input type="checkbox"/> Instruction manual	
<input type="checkbox"/> Acceptance report/Documentation of fastenings / photo-documentation	
PPE (Personal Protective Equipment for fall protection) : Inspection according to manufacturer's instructions	
<input type="checkbox"/> Date of expiry	
<input type="checkbox"/> routine annual inspection conducted	
<input type="checkbox"/> not inspected (no authorisation)	
ROOF SEAL:	
<input type="checkbox"/> no damage	
<input type="checkbox"/> no corrosion	
VISIBLE PARTS OF THE FASTENINGS	
<input type="checkbox"/> no deformation	
<input type="checkbox"/> no corrosion	
<input type="checkbox"/> screw fastenings secure	
<input type="checkbox"/> tightening torque of screw fastenings	
<input type="checkbox"/> firmly positioned	
STAINLESS STEEL CABLE:	
<input type="checkbox"/> optical check	
<input type="checkbox"/> cable strands	
<input type="checkbox"/> ...	

INSPECTION REPORT NR. _____ (Part 2/2)

TEMPORARY LIFELINE SYSTEM Ø 10MM AS PER EN 795 TYP C

INSPECTION POINTS:

 checked and in order!

OBSERVED DEFECTS:

(Description of defect/ Measures to be taken)

INTERMEDIATE BRACKETS:

 no deformation welding seams screw fastenings secure

CORNER FASTENINGS:

 no deformation welding seams ...

END FASTENINGS:

 no deformation welding seams ...

END LOCKS:

 cable properly positioned indicator clamp cable pretension inspection of welding points (crevice corrosion) ...

SLIDERS: Type: INNOTECH "IND-GLEIT-..."

 screw fastenings secure sliding gap (see instruction manual) original INNOTECH karabiners (as per EN 362) ...

INCORPORATION IN THE LIGHTNING PROTECTION SYSTEM:

(according to applicable lightning protection regulations):

 screw fastenings secure clamps not inspected ...

Result of acceptance: The safety system matches the manufacturer's instruction manual and the latest technological standards. Its safety and reliability is hereby confirmed.

Comments: _____

Name: _____

Customer

Inspection: Contractor (Qualified professional familiar with the fall prevention system)

Date, company seal, signature_____
Date, company seal, signature

INNOTECH Arbeitsschutz GmbH, Laizing 10, A-4656 Kirchham/Austria
www.innotech.at

